

# SPRAY-APPLIED TECHNOLOGIES

Exceed Performance Criteria  
every code. every climate. every application.



What do you want your next project to be known for? Energy efficiency? Durability? Environmental stewardship? Comfort? Design? Whatever your goal, our high-performance polyurethane technologies are engineered for your success.

From industry-leading insulating air barrier systems for commercial and residential construction, to almost-indestructible roofing systems, the versatility of chemistry lets you specify a material to meet and exceed performance criteria for every code and climate.

Our polyurethane technologies are two-component products, engineered in the molecular level for specific applications and performance attributes. Spray-applied and seamless, they conform exactly to any shape or contour, locking in leak-free comfort and energy efficiency. With a closed-cell content greater than 90 percent, they offer increased structural strength, long life-expectancy and low lifecycle cost.

Helping Make  
Buildings Better™

  
The Chemical Company

BASF Polyurethane  
Foam Enterprises LLC

## Engineered for roofs.

High-performance ELASTOSPRAY® roofing systems for commercial buildings provide seamless, leak-free protection from the elements with some of the highest wind uplift and hail resistance ratings in the industry. Spray-applied, the systems are self-flashing and handle unusual shapes, elevations and slope-to-drain requirements with ease. In retrofit situations, ELASTOSPRAY systems can be applied directly to the existing substrate in most cases, avoiding a costly tear-off and diverting thousands of pounds of waste from the landfill. The superior insulation performance of ELASTOSPRAY polyurethane foam contributes to improved building energy efficiency, and when combined with ENERGY STAR®-rated ELASTOCOAT™ reflective coatings can help lower rooftop temperatures for reduced urban heat island effect.

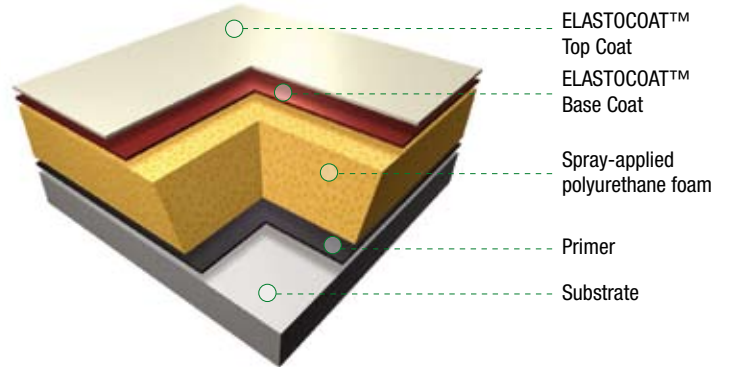

Why make holes in your leak-proof roof? AmeriGlue™ polyurethane insulating adhesive makes leaks caused by nails and screws a thing of the past. AmeriGlue adhesive helps lower labor costs and provides an almost-silent application for reduced disruption to building occupants. AmeriGlue adhesive fully adheres to most building materials, including non-nailable decks like concrete or gypsum. And while mechanical fasteners often add to thermal bridging, the seamless, monolithic AmeriGlue adhesive eliminates temperature transmission to provide improved building energy efficiency and durability. Spray-applied and expanding, AmeriGlue polyurethane adhesive fills gaps and seams between insulation boards to recover the R-value loss these gaps can cause. AmeriGlue polyurethane adhesive has multiple wind uplift resistance credentials from third-party testing laboratories including UL and FM.

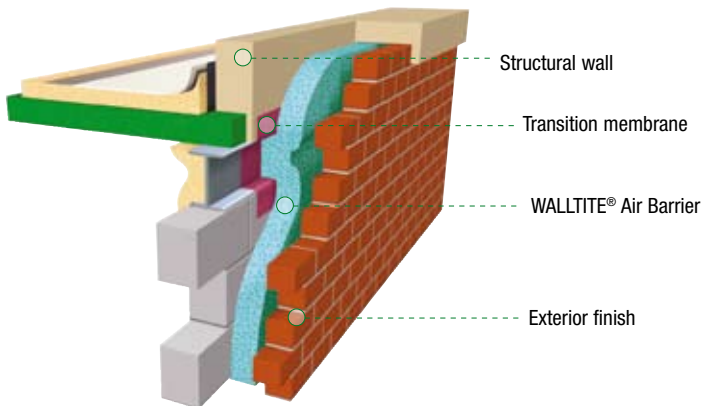
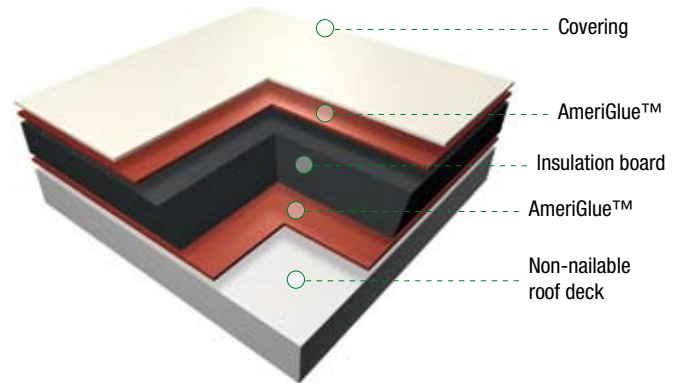

## Engineered for walls.

WALLTITE® technology is the highest-performing combination insulation and air barrier system available today. With an insulation R-value of more than 6.0 per inch and an air permeability rating of <math><0.001 \text{ L/s/m}^2 @ 75 \text{ Pa}</math> at 1.5-inch thickness, the WALLTITE system makes a significant contribution to improved energy efficiency, durability and comfort in multi-unit residential and commercial buildings. The United States Department of Energy estimates that 40 percent of the cost of heating and cooling a building is lost to uncontrolled air leakage, which can also lead to premature building deterioration, condensation and mold. WALLTITE technology eliminates uncontrolled air leakage. Rigid, self-adhering and seamless, it adds structural strength and offers a life expectancy greater than the service life of the building. The WALLTITE system is approved by the Air Barrier Association of America to meet the Commercial State Energy Codes of Massachusetts, Wisconsin and Michigan.

### Engineered for houses.

COMFORT FOAM® technology is the two-for-one solution for residential builders – a fully-tested, field-proven combination insulation and air barrier system. Spray-applied and fully-adhered, the COMFORT FOAM system eliminates uncontrolled air leakage, convection looping, thermal bridging and condensing surfaces for improved comfort and energy efficiency. It also prevents moisture-related problems such as mold infestations, ice damming and rot. New homes built with COMFORT FOAM technology may be eligible for energy efficiency incentives under the Federal Energy Policy Act 2005. COMFORT FOAM insulation is accepted by all major building codes, including the International Code Council encompassing both commercial and residential applications. Closed-cell polyurethane foam is classified as 'acceptable flood-resistant material' by the Federal Emergency Management Agency (FEMA)<sup>1</sup>.

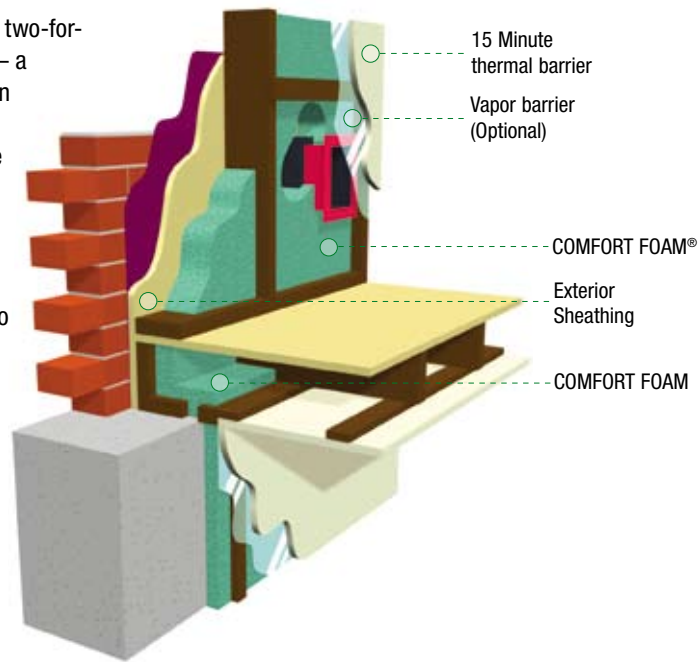

### Engineered for joints.

ZERODRAFT® insulating air sealants create air barrier continuity within the building envelope. At intersections and transition points, ZERODRAFT Two-Component Polyurethane Insulating Air Sealants and One-Component Polyurethane Foam Sealants are installed from within the building structure to seal and insulate critical 'hard-to-build' areas, such as windows, doors, penetrations, parapets and soffits. By sealing gaps, cracks, leaks and holes within the building envelope and creating air barrier continuity, ZERODRAFT foam sealants have helped lower energy demand and consumption in all types of commercial, institutional, multi-unit and single-family residential buildings – both new construction and retrofit – across North America.

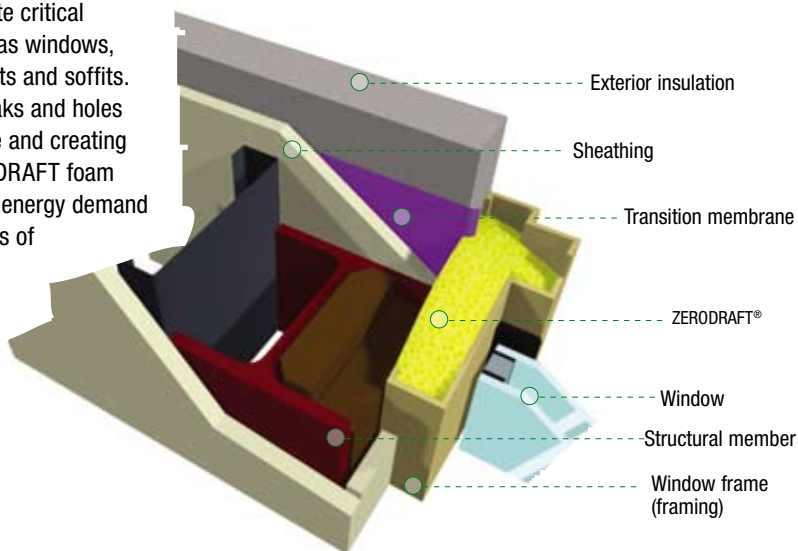

## Engineered for environmental responsibility.

Our polyurethane technologies, developed using ZONE3® zero-ozone-depleting blowing-agent technology, can help reduce energy consumption, fossil fuel emissions and landfill waste.

Designed to harmonize ecology and economy, the award-winning<sup>2</sup> BASF Eco-Efficiency Analysis assesses the lifecycle of a product or manufacturing process from the “cradle to the grave” over five categories:

- Resource utilization
- Energy consumption
- Emissions to air, water and soil
- Toxicity potential
- Misuse and Risk potential

Eco-Efficiency Analysis is applied in order to use as few materials and energy as possible in producing our products and to keep emissions as low as possible. At the same time, our products must help our customers conserve resources. Both the WALLTITE system and ELASTOSPRAY technology outperformed traditional materials in eco-efficiency on their test scores.

To request detailed Eco-Efficiency Analysis results, or find out how our polyurethane technologies can help your construction project attain points under Leadership in Energy and Environmental Design (LEED®) rating systems, visit [www.basf-pfe.com](http://www.basf-pfe.com)

## The role of the world's leading chemical company.

BASF Polyurethane Foam Enterprises is the only manufacturer to offer a complete engineered building envelope system, including spray-applied polyurethane foam for all types of buildings, Eco-Efficiency Analysis, a full system warranty and a single source supply of silicone, urethane, polyurea and acrylic coating solutions for the commercial roofing market.

As demand for sustainable construction materials and applications continues to grow, BASF Polyurethane Foam Enterprises offers new cost-effective solutions, developed at extensive R&D facilities around the corner and around the world.

<sup>1</sup> Technical Bulletin 2-93, Flood-Resistant Materials Requirements for Buildings Located in Special Flood Hazard Areas, Federal Emergency Management Agency, 1993

<sup>2</sup> 2005 awards include: the Design for Sustainability Award (Society of Plastics Engineers), the Presidential Green Chemistry Challenge Award (U.S. Environmental Protection Agency) and the Best Sustainable Practice Award in the Sustainable Research, Development, Construction Process and Demonstration (Sustainable Buildings Industry Council)

### BASF Polyurethane Foam Enterprises LLC

13630 Watertower Circle  
Minneapolis, MN 55441  
Phone: 713-559-3266  
Fax: 713-383-4592  
[www.basf-pfe.com](http://www.basf-pfe.com)  
[spfinfo@basf.com](mailto:spfinfo@basf.com)

363-1160



SEE US IN



COMFORT FOAM® is registered trademark of BASF Polyurethane Foam Enterprises LLC.

WALLTITE®, ELASTOSPRAY®, ELASTOCOAT™, ZONE3® and Helping Make Buildings Better™ are trademarks of BASF Corporation.

ZERODRAFT® is a registered trademark of Canam Building Envelope Specialists Inc.

LEED® is a registered trademark of the United States Green Building Council.

ENERGY STAR® is a registered trademark of the United States Department of Energy.

© 2006 BASF Polyurethane Foam Enterprises LLC